

The effect of post-traumatic stress disorder on refugees' parenting and their children's mental health: a cohort study

Richard A Bryant, Ben Edwards, Mark Creamer, Meaghan O'Donnell, David Forbes, Kim L Felmingham, Derrick Silove, Zachary Steel, Angela Nickerson, Alexander C McFarlane, Miranda Van Hooff, Dusan Hadzi-Pavlovic



Summary

Background Children and adolescents, who account for most of the world's refugees, have an increased prevalence of psychological disorders. The mental health of refugee children is often associated with the severity of post-traumatic stress disorder (PTSD) in their caregivers. Despite the potential for refugee caregivers' PTSD to affect child mental health, little evidence exists concerning the underlying mechanisms of this association. This study tested the effect of refugee caregivers' previous trauma and levels of ongoing stressors on current PTSD, and in turn how this influences parenting behaviour and consequent child psychological health.

Methods This cohort study recruited participants from the Building a New Life in Australia study, a population-based prospective cohort study of refugees admitted to 11 sites in Australia between October, 2013, and February, 2014. Eligible participants were aged 18 years or older and the principal or secondary applicant (ie, the refugee applicant within a migrating family unit) for a humanitarian visa awarded between May, 2013, and December, 2013. Primary caregiver PTSD and postmigration difficulties were assessed at Wave 1 (in 2013), and caregiver PTSD was reassessed at Wave 2 (in 2014). At Wave 3, between October, 2015, and February, 2016, primary caregivers repeated measures of trauma history, postmigration difficulties, probable PTSD, and harsh and warm parenting style, and completed the Strengths and Difficulties Questionnaire for their child. We used path analysis to investigate temporal patterns in PTSD, trauma history, postmigration stressors, parenting style, and children's psychological difficulties.

Findings The current data comprised 411 primary caregivers who provided responses in relation to at least one child (660 children). 394 primary caregivers with 639 children had data on independent variables and were included in the final model. Path analyses revealed that caregivers' trauma history and postmigration difficulties were associated with greater subsequent PTSD, which in turn was associated with greater harsh parenting and in turn, higher levels of child conduct problems ($\beta=0.049$, $p=0.0214$), hyperactivity ($\beta=0.044$, $p=0.0241$), emotional symptoms ($\beta=0.041$, $p=0.0218$), and peer problems ($\beta=0.007$, $p=0.047$). There was also a direct path from primary caregiver PTSD to children's emotional problems ($\beta=0.144$, $p=0.0001$).

Interpretation PTSD in refugees is associated with harsh parenting styles, leading to adverse effects on their children's mental health. Programmes to enhance refugee children's mental health should account for PTSD in parents and caregivers, and the parenting behaviours that these children are exposed to.

Funding National Health and Medical Research Council.

Copyright © 2018 The Author(s). Published by Elsevier Ltd. This is an Open Access article under the CC BY-NC-ND 4.0 license.

Introduction

According to the UN High Commissioner for Refugees, there are currently more than 22.55 million refugees worldwide.¹ Overwhelming evidence exists that refugees have an increased prevalence of mental disorders, including depression, post-traumatic stress disorder (PTSD), and anxiety.² Child and adolescent refugees, who account for more than half of the world's refugees, have a higher prevalence of mental disorders than children and adolescents who are not refugees.³ Impaired psychological health in refugee children and adolescents can be largely attributed to war experiences, stresses in transition such as detention, postmigration stressors, and acculturation difficulties.⁴

The mental health of refugee parents might also have an important role in child refugee mental health.⁴ Many studies have investigated the mental health status of the offspring of trauma-affected populations, with particular focus on the children of Holocaust survivors. One meta-analysis⁵ of 32 studies found a relation between Holocaust survivors' negative mental states and their children's psychological problems. In terms of refugees, the evidence of an association between parent and child mental health status^{6,7} is mixed, although one meta-analysis⁸ of 42 studies reported a significant effect of parental PTSD on child mental difficulties ($r=0.35$). However, a major limitation of many of these studies is the reliance on small and non-representative samples, which restricts confidence in the

Lancet Public Health 2018; 3: e249-58

See [Comment](#) page e211

School of Psychology (Prof R A Bryant PhD, A Nickerson PhD) and School of Psychiatry (Prof D Silove MD, Prof Z Steel PhD, D Hadzi-Pavlovic MPsych), University of New South Wales, Sydney, NSW, Australia; Westmead Institute for Medical Research, Sydney, NSW, Australia (Prof R A Bryant); Centre for Social Research and Methods, Australian National University, Canberra, Australian Capital Territory, Australia (B Edwards PhD); Phoenix Australia (Prof M Creamer PhD, Prof M O'Donnell PhD, Prof D Forbes PhD) and School of Psychological Sciences (Prof K L Felmingham PhD), University of Melbourne, Melbourne, VIC, Australia; and Centre for Traumatic Stress Studies, University of Adelaide, Adelaide, SA, Australia (Prof A C McFarlane MD, M Van Hooff PhD)

Correspondence to: Prof Richard Bryant, School of Psychology, University of New South Wales, Sydney, NSW 2052, Australia
r.bryant@unsw.edu.au

Research in context

Evidence before this study

We systematically reviewed MEDLINE for studies about refugees, parenting, and the mental health of children published in English between database inception and Sept 30, 2017, using the following search terms: "refugees", "asylum seekers", "displaced persons", "mental health", "posttraumatic stress disorder", "parenting", and "children". Some small studies provide initial evidence that refugees' mental health is associated with children's mental health. Although evidence exists in non-refugees that parental mental health is associated with parenting behaviour that can adversely affect children's psychological wellbeing, this pattern has not been investigated in refugee populations. In summary, to our knowledge, no large-scale or population-based studies have been done assessing the associations between refugees' trauma histories, mental health, and parenting styles, and their children's mental health.

Added value of the study

This study used three waves of the Building a New Life in Australia survey, including 411 adult refugees and 660 children, to provide the first large-scale population-based investigation

of the effect of refugees' experiences, mental health, and parenting behaviour on the mental health outcomes of their children. We show for the first time that refugees' trauma experiences and postmigration difficulties affect their mental health, which can also affect their children's psychological wellbeing. Specifically, traumatic experiences and postmigration stressors contribute to refugees' post-traumatic stress disorder, which in turn contributes to harsh parenting, which in turn is associated with poorer mental health outcomes of refugee children.

Implications of all the available evidence

These findings suggest that one adverse effect of post-traumatic stress disorder in refugees is that the resulting harsh parenting can contribute to poorer mental health in their children. This pattern suggests that refugee children's psychological wellbeing could be improved by either alleviating the post-traumatic stress disorder of their caregivers or teaching refugees supportive parenting behaviours.

validity of findings. Furthermore, previous studies have typically adopted cross-sectional designs, which preclude analysis of the cumulative effects of parental mental health over time on children's mental health.

Although most researchers infer that the association between refugee caregivers' mental health and their children's psychological wellbeing can be attributed to a disturbed parenting style, inadequate evidence is available to support this assumption. Evidence suggests that clinical depression or anxiety influence parenting behaviours, which in turn increase risk of both internalising and externalising problems in children.⁹ Some preliminary evidence suggests that exposure to interpersonal trauma can result in overprotective or harsh parenting or reversal of parent-child roles, which can adversely affect children's mental health.¹⁰ There is also evidence that how parents cope with stress can affect the mental health of refugee children, including an association between mental health problems and anger being directed to children,¹¹ and that parental or family cohesion can moderate children's mental health.¹² Despite this suggestive evidence, how refugee caregivers' mental health affects parenting style and the mental health of children needs to be specifically investigated in large representative samples.

The present study aimed to extend existing research by indexing a large, longitudinal, representative sample of resettled refugees and their children and then specifically assessing the effect that history of trauma and postmigration stress had on the mental health of the caregiver, the consequent effect of the caregiver's mental health issues on their parental style, and how parenting style affected children's mental health.

To overcome the limitation of previous cross-sectional studies, we investigated these pathways longitudinally by assessing parental PTSD annually for 2 years before reassessing parental PTSD, current parenting style, and children's mental health in the third year of the study. We hypothesised that trauma experience and postmigration difficulties would predict higher PTSD levels in the primary caregiver, which over time would cumulatively be associated with harsh parenting style and reduced warm parenting, which in turn would contribute to poorer psychological functioning in refugee children.

Method

Study design and participants

This cohort study is based on the Building a New Life in Australia (BNLA) study done by the Australian Government Department of Social Services.¹³ The BNLA is a longitudinal, population-based, cohort study of refugees recruited at the time of being granted permanent humanitarian visa status. The initial wave of data collection occurred between October, 2013, and February, 2014. Subsequent waves were conducted annually, with Wave 3 data being collected between October, 2015, and February, 2016. BNLA participants were recruited from 11 sites across Australia, encompassing major cities and regional areas that reflected concentrations of eligible refugees across visa classes. The BNLA study obtained ethics approval from the Australian Institute of Family Studies Human Research Ethics Committee.

Eligibility criteria for the BNLA included being the principal or secondary applicant (ie, the refugee applicant within a migrating family unit) for a humanitarian visa

awarded between May, 2013, and December, 2013, and being 18 years or older. Eligible principal applicants consented for their migrating unit to participate and for other adult members of their migrating unit to be invited to participate. These secondary applicants were then invited to participate in the BNLA study if they were residing with the principal applicant. All participants provided written informed consent following explanation of the study.

Procedures

Data for Waves 1 and 3 were collected via face-to-face interview, whereas data for Wave 2 were collected via telephone interview. Interviews were done using computer-assisted personal interview and computer-assisted self-interview. Computer-assisted personal interview enabled field interviewers to ask questions displayed on the screen and enter responses from the participant directly into a computer. Computer-assisted self-interview allowed for participants to respond privately to self-report questions using a computer interface (assistance provided when needed). Interview questions and associated written material were translated from English into nine languages, including Arabic, Burmese, Dari, Hazaragi, Persian, Chin Haka, Nepali, Swahili, and Tamil. In most cases, participants were matched with an interviewer who was a native speaker of their respective language; however, few participants opted for translated or interpreted interviews.

The Wave 3 data were collected after a residency period of 2–3 years in Australia, and unlike the previous waves included an assessment of participants' children. Specifically, the person recognised within the family unit as the primary caregiver (not necessarily the primary refugee applicant) was invited to complete a child module with respect to up to two children in their care; if a migrating unit had more than two eligible children, two children were randomly selected.

Two principles were applied to sampling children: one to two children from each family could participate; and older children (aged 11–17 years at Wave 3) were preferentially selected over younger children (aged 5–10 years) because the older children were able to provide self-report responses in addition to parental reports. On the basis of these criteria, children and adolescents were selected by randomly selecting up to two children aged 11–17 years in each migrating unit. In migrating units with two or more children aged 11–17 years old, two children in this age group were randomly selected. In migrating units with only one child aged 11–17 years and several younger children aged 5–10 years, the older child and one randomly selected younger child would be given the parental report child module of the assessment. In the migrating units with only children aged 5–10 years, up to two children in this age group were randomly selected.

To ensure consistency in the response formats of younger and older children's Strengths and Difficulties Questionnaire (SDQ) scores, we focused on the

caregivers' reports of their children for all children. A list-wise deletion approach is used by the statistical program used for the analysis (Mplus, version 8), such that if information for an independent variable were missing, then the primary caregiver and their child's data were excluded from the model. Missing data on dependent variables did not result in exclusion under the full information maximum likelihood model.

The face-to-face interview assessed a broad range of demographic and migrating unit factors, including PTSD, trauma history, postmigration stressors, parenting style, and children's psychological difficulties.

The Post-Traumatic Stress Disorder–8 items (PTSD-8)¹⁴ is an eight-item self-reported screening measure for probable PTSD derived from the Harvard Trauma Questionnaire¹⁵ and used to assess caregivers' PTSD symptoms. The PTSD-8 is designed to assess trauma symptoms in refugee populations, and assesses four intrusion, two avoidance, and two hypervigilance items. Participants rate the symptoms on a four-point Likert scale (1 [not at all] to 4 [most of the time]), reporting how much the symptoms bothered them in the past week. Probable diagnosis of PTSD is met if at least one symptom from each of the three PTSD-8 subscales has an item score of 3 or 4 (indicating the symptom is present "sometimes" or "most of the time" for at least one item in each subscale).¹⁴ This measure was administered at all three waves and had an internal consistency (Cronbach's alpha) of 0.91 to 0.92 across waves.

To assess the extent of exposure to traumatic events, at Wave 3, caregivers were administered a modified version of the Harvard Trauma Questionnaire Trauma Events Module¹⁶ that indexed ten potentially traumatic events. This measure comprises events that are relevant to refugee experience (eg, combat exposure, imprisonment, and murder or disappearance of family members) and has been widely used with refugee populations.¹⁷ At Wave 1, respondents were asked non-specifically whether they, or someone in their family, had experienced certain traumatic events. These responses were summed to create a score for family trauma. These two measures were analysed separately in the model.

The BNLA indexed postmigration stressors commonly experienced by refugees during resettlement. Specifically, respondents were asked to dichotomously indicate if any of ten life events caused them stress. Events included work, housing, finances, family safety, discrimination, school or study, caring for family, conflict with neighbours, language barriers, or acculturation. These questions were asked at Wave 1 (nine only because conflict with neighbours was not included) and at Wave 3 (all ten).

To index parenting style, caregivers were assessed for both warmth and harsh dimensions of parenting style derived from questionnaires used in the Longitudinal Study of Australian Children.¹⁸ The warmth scale was derived from the Child Rearing Questionnaire,¹⁹

and comprised five items that indexed parental displays of affection and awareness of the child's needs. The hostility scale was derived from the Early Childhood Longitudinal Study of Children,²⁰ and included items regarding negativity, use of physical discipline, and rigid enforcement of rules. We note that different aspects of parenting have been associated with children's mental health; however, our intention was to measure constructs that would broadly encompass positive and negative parenting behaviours. Accordingly, although not encompassing all aspects of parenting, the dimensions of warm and harsh parenting were selected as the constructs of interest because they have been shown to affect positive and negative childhood mental health, respectively.²¹ In this study, the internal consistency of the warmth scale was 0.73 and the hostility scale was 0.74.

The SDQ²² was used to assess children's psychological difficulties at Wave 3 only. The SDQ comprises 25 items measuring behavioural, emotional, and social problems that can be scored by caregivers or children. It is a well validated questionnaire consisting of five subscales: conduct problems, hyperactivity, emotional symptoms, peer problems, and prosocial behaviour (this analysis focuses on the four difficulties subscales, excluding the prosocial scale). In this study, parents were asked to rate each of the items regarding their child for the past 6 months on a three-point Likert scale (0 [not true] to 2 [certainly true]). All but prosocial behaviour items were summed to generate a total difficulties score (0–40). The internal consistency of the SDQ is 0.80 to screen for child psychiatric disorders, including in non-western populations,¹⁶ and is a broad measure of both internalising and externalising problems in young refugees. The SDQ is a widely used measure of adjustment among refugee populations and has similar factor structures across ethnic groups.²³

Statistical analysis

We investigated the temporal pattern of associations of the independent variables (PTSD, trauma history, postmigration stressors, parenting style, and children's psychological difficulties) with child SDQ scale scores using path analysis. In addition to the measures described, we included the gender and age of both the caregiver and the child as potential covariates in the model. In models of this kind, the possibility of different models by gender (of either child or caregiver) arises. Because of the limited sample size, we chose not to do multiple-group analyses or to include by-gender interaction terms. The path model respected the longitudinal sequence of the measurements. Because psychosocial measures assessed at each wave were cross-sectional, the path model was further defined so that, within waves, paths reflected either the implied temporal order (eg, pre-arrival trauma preceded other Wave 1 variables); the causal order, which is favoured in the scientific literature (eg, postmigration stressors affect

PTSD at the same wave, although potentially in either direction longitudinally); or the primary hypothesis, namely that SDQ was the endpoint (thus, for example, SDQ was not allowed to cause harsh parenting). Within this framework, a sequence of models was fitted, with paths identified either from theory or through the use of modification indices. After a model was fitted, statistically non-significant paths were removed and then the model re-fitted; as such, the final reported model is restricted to significant paths. We did not attempt to improve model fit by including correlated residuals so as to not potentially inflate the apparent fit of the path component. Because several primary caregivers provided reports on two children, we analysed the data as a complex sample, with the family identified as the clustering unit. All analyses were done using Mplus, version 8.²⁴

Role of the funding source

The funder of the study had no role in study design, data collection, data analysis, data interpretation, or writing of the report. The corresponding author had full access to all the data in the study and had final responsibility for the decision to submit for publication.

Results

Of 2399 participants in the BNLA overall, 1894 (79%) had data for Wave 3, of which 426 (22%) were primary caregivers of children who were eligible for inclusion in this analysis. Among the 426 caregivers who were eligible, 409 (96%) completed the child module. The data for the current analyses are drawn from 426 primary caregivers; however, because of missing data on the SDQ, this number reduced to 411 (96%) eligible primary carers (303 [74%] mothers, 95 [23%] fathers, and 13 [3%] other members of the migrating unit) who completed the child module for at least one child (660 children). Missing data on independent variables in the final model further reduced the analytical sample to 394 caregivers (92 [23%] fathers, 288 [73%] mothers, and 14 [4%] other) reporting on 639 children.

Of the 394 caregivers who contributed data to the final model, most were female and from migrating units with two caregivers (table 1). Approximately half of the 639 children analysed were female. Among the 394 caregivers included in the sample, 314 (80%) originated from Iraq or Afghanistan; 33 (8%) from Bhutan or Myanmar; 26 (7%) from Iran; seven (2%) from Libya, Syria, or Egypt; and 14 (4%) from elsewhere. 147 (38%) of 384 caregivers had probable PTSD at Wave 3. In terms of the mental health of children, 42 (7%) of 639 children scored above the cutoff for psychological difficulties (≥ 20 on SDQ).

The reduced model of standardised direct and indirect paths from trauma and postmigration stressors to caregiver PTSD, parenting style, and child mental health outcomes yielded an adequate fit ($\chi^2=223.4$ [88 degrees of freedom]; $p<0.0001$; Comparative Fix Index=0.882;

	Male	Female	Distribution	Degrees of freedom	p value
Primary caregivers in final model					
Overall sample	97 (25%)	297 (75%)
Age (years)					
Mean (SD)	44.4 (9.4)	38.9 (8.1)	t=5.5	392	<0.0001
<25	2/97 (2%)	9/297 (3%)	$\chi^2=18.9$	3	0.0003
25–34	11/97 (11%)	81/297 (27%)
35–44	38/97 (39%)	129/297 (43%)
≥45	46/97 (47%)	78/297 (26%)
Family structure					
Couple family	85/92 (92%)	196/297 (66%)
Single parent family	4/92 (4%)	98/297 (33%)
Other	3/92 (3%)	3/297 (1%)
Probable PTSD (at Wave 1)	38/97 (39%)	116/289 (40%)	$\chi^2=0.03$	386	0.8669
Probable PTSD (at Wave 2)	29/87 (33%)	92/262 (35%)	$\chi^2=0.09$	349	0.7623
Probable PTSD (at Wave 3)	37/95 (39%)	110/289 (38%)	$\chi^2=0.02$	384	0.8776
Trauma exposure total*	2.35 (2.12)	2.65 (2.10)	t=1.15	363	0.2490
Family trauma total*	2.10 (1.57)	2.08 (1.30)	t=0.19	392	0.8733
PTSD (at Wave 1)	9.13 (7.58)	9.86 (7.22)	t=0.84	384	0.3992
PTSD (at Wave 2)	8.39 (6.81)	8.38 (6.94)	t=0.00	347	0.9879
PTSD (at Wave 3)	9.02 (7.25)	9.44 (7.01)	t=0.50	382	0.6141
Postmigration stress† (at Wave 1)	2.98 (2.05)	2.67 (1.86)	t=1.36	380	0.1753
Postmigration stress† (at Wave 3)	2.97 (1.89)	2.89 (1.98)	t=0.50	382	0.7291
Children of primary caregivers in final model					
Overall sample	346 (54%)	293 (46%)	$\chi^2=4.40$	1	0.0360
Children with primary caregiver data					
One caregiver in migrating unit	79/346 (23%)	62/293 (21%)
Two caregivers in migrating unit	267/346 (77%)	231/293 (79%)
Age (years)					
Mean (SD)	12.08 (3.56)	12.03 (3.46)	F=0.03‡	395	0.8751
5–9	91/346 (26%)	72/293 (25%)	$\chi^2=0.948$	3	0.8139
10–12	86/346 (25%)	76/293 (26%)
13–15	96/346 (28%)	89/293 (30%)
16–18§	73/346 (21%)	56/293 (19%)
Parent SDQ¶					
Emotional problems	2.05 (2.08)	2.51 (2.42)	F=6.66‡	395	0.102
Conduct problems	1.38 (1.55)	1.38 (1.60)	F<1‡	395	0.9954
Hyperactivity problems	3.19 (2.26)	2.76 (2.07)	F=7.00‡	395	0.0085
Peer problems	2.27 (1.56)	2.56 (1.55)	F=5.35‡	395	0.0212
Parenting¶¶					
Harsh	9.43 (3.66)	9.24 (3.69)	F<1‡	379	0.5206
Warm	12.19 (3.42)	12.68 (2.92)	F=4.43‡	379	0.0356

Data are n (%) or mean (SD), unless stated otherwise. PTSD=post-traumatic stress disorder. SDQ=Strengths and Difficulties Questionnaire. *Indicates mean (SD) number of different types of traumatic events experienced by participants. †Indicates mean (SD) number of different types of postmigration stressors reported by participants. ‡The F and its associated degrees of freedom are based on incorporating the clustering. §Only two children are aged 18 years. ¶The means and SDs are observed values. The analysis of complex samples routinely does not produce SDs, but only SEs that reflect the clustering, and enter in the F tests. We have not attempted to calculate comparable SDs.

Table 1: Participant characteristics

Tucker-Lewis Index=0.830; root mean square error of approximation=0.049; figure).

We tested several mediated pathways between caregiver PTSD by way of harsh parenting to child's mental health (ie, internalising and externalising behaviour). The influence of PTSD at Wave 3 had an indirect effect via

harsh parenting for three of the four SDQ scales mediated via the association between PTSD and harsh parenting (standardised indirect: emotional problems [$\beta=0.041$, $p=0.0218$]; conduct problems [$\beta=0.049$, $p=0.0214$]; hyperactivity problems [$\beta=0.044$, $p=0.0241$]; and peer problems [$\beta=0.022$, $p=0.0513$]). Additionally,

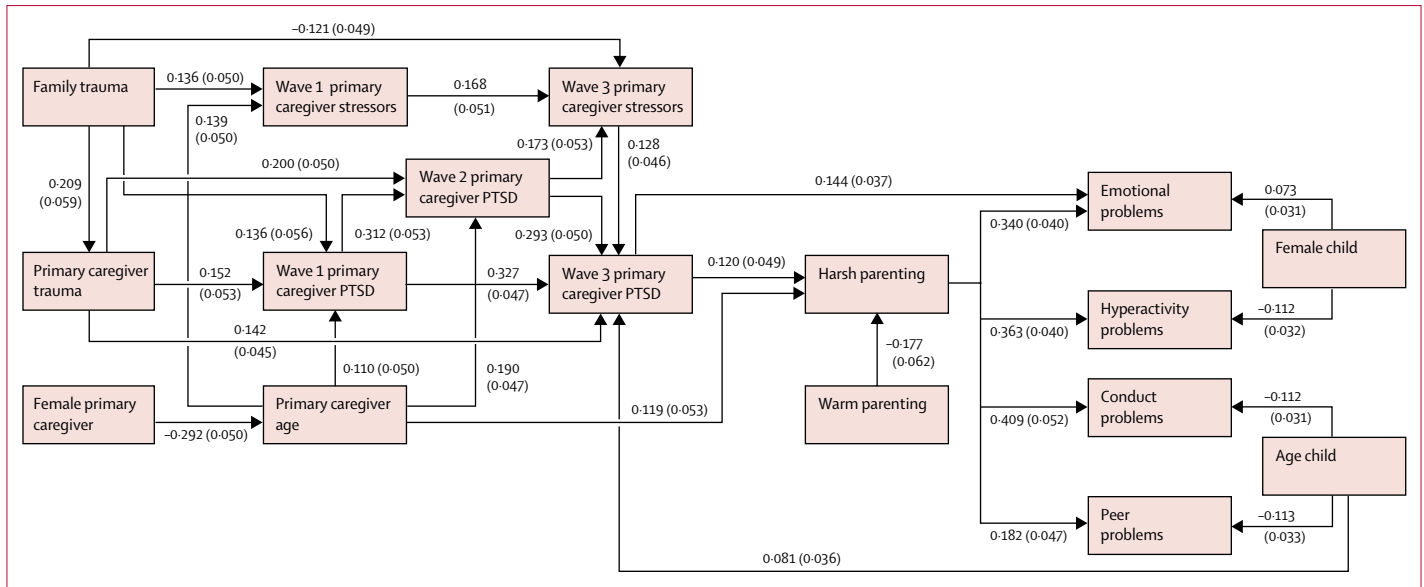

Figure: Final structural equation model of the direct associations between caregiver trauma history, postmigration stress, and PTSD severity with parental style and children's mental health. Data are standardised regression weights (SE). The reduced model shows significant standardised direct paths from trauma and postmigration stressors to caregiver PTSD at Wave 1, then to PTSD at Wave 2, and to these factors as well as parenting style, and child mental health outcomes at Wave 3. PTSD=post-traumatic stress disorder.

Wave 3 PTSD also had a direct association with child SDQ emotional problems (direct $\beta=0.144$, $p=0.0001$), accounting for 78% of the variation in emotional problems. As such, the greater the primary caregiver symptoms of PTSD, the harsher their parenting, and in turn, the higher the levels of conduct problems, hyperactivity, emotional symptoms, and peer problems of their children (table 2). PTSD from earlier waves had an indirect effect on Wave 3 SDQ scores (Wave 1 PTSD: emotional problems, total indirect $\beta=0.079$, $p<0.0001$; conduct problems, total indirect $\beta=0.021$, $p=0.0176$; hyperactivity problems, total indirect $\beta=0.019$, $p=0.0201$; peer problems, total indirect $\beta=0.009$, $p=0.0455$), suggesting that previous PTSD had long-term associations with child mental health via the subsequent PTSD levels of caregivers. Additionally, there was an indirect path from Wave 1 PTSD to harsh parenting via Wave 3 PTSD (total indirect $\beta=0.039$, $p=0.0133$).

Caregiver exposure to trauma, both individual and for the migrating unit, was associated with child wellbeing, through the PTSD–harsh parenting pathway. There were significant indirect pathways from caregiver trauma to emotional problems (total indirect $\beta=0.056$, $p=0.0002$), conduct problems (total indirect $\beta=0.015$, $p=0.0261$), and hyperactivity problems (total indirect $\beta=0.013$, $p=0.0298$), but not peer problems (total indirect $\beta=0.007$, $p=0.0549$).

Increased postmigration stressors (primarily at Wave 1) were associated with higher levels of conduct problems (for Wave 1 stressors, total standardised indirect $\beta=0.005$, $p=0.0403$), hyperactivity (indirect $\beta=0.005$, $p=0.0469$), and emotional symptoms (indirect $\beta=0.020$, $p=0.0029$), but not peer problems, via elevated primary caregiver PTSD symptoms, and in turn, increased harsh parenting. For Wave 3 postmigration stressors, the only significant

effect was on emotional problems ($\beta=0.024$, $p=0.0257$). This association was primarily mediated by the direct effect of PTSD on emotional problems (75% of the indirect association) rather than via harsh parenting (25% of the indirect association). To gauge the effects of the missing data, we reran the final model with 50 imputed datasets without the complex data option, because Mplus does not allow multiple imputation with complex data, and found no significant differences.

Discussion

The finding that 38% of the adult caregivers assessed in this sample had probable PTSD at the Wave 3 assessment point is consistent with many studies, highlighting the increased risk of PTSD in refugee populations.² The path model identified significant direct associations from levels of caregiver PTSD at Wave 1 to Wave 2, and subsequently to Wave 3, which accords with previous longitudinal studies documenting the chronicity of PTSD among refugee populations across the early resettlement period.²⁵ Caregiver levels of PTSD were in turn related to childhood emotional difficulties, which accords with a large body of research in parallel fields of study reporting an association between parental PTSD and childhood psychological difficulties.^{4,5,8}

Although we acknowledge that path analyses do not permit conclusions regarding causation, the important advance of the current finding is that it delineates how caregiver PTSD is associated with harsh parenting, which adversely affects childhood mental health. Although the strength of the association between caregiver PTSD and hostile parenting was moderate, it was of large

	Standardised estimate (SE)	Z	p value	Non-standardised estimate (SE)	Z	p value
Primary caregiver trauma						
Family trauma	0.209 (0.059)	3.528	0.0004	0.317 (0.095)	3.355	0.0008
Wave 1 primary caregiver stress						
Family trauma	0.136 (0.050)	2.725	0.0064	0.184 (0.067)	2.741	0.0061
Primary caregiver age	0.139 (0.050)	2.760	0.0058	0.031 (0.011)	2.773	0.0056
Wave 1 primary caregiver PTSD						
Primary caregiver age	0.110 (0.050)	2.216	0.0267	0.095 (0.043)	2.229	0.0258
Family trauma	0.136 (0.056)	2.428	0.0152	0.725 (0.300)	2.415	0.0157
Primary caregiver trauma	0.152 (0.053)	2.901	0.0037	0.536 (0.189)	2.839	0.0045
Wave 1 primary caregiver stress	0.203 (0.054)	3.780	0.0002	0.795 (0.210)	3.794	0.0001
Wave 2 primary caregiver PTSD						
Primary caregiver age	0.190 (0.047)	4.085	<0.0001	0.157 (0.039)	4.053	<0.0001
Primary caregiver trauma	0.200 (0.050)	3.989	<0.0001	0.665 (0.166)	4.012	<0.0001
Primary caregiver Wave 1 PTSD	0.312 (0.053)	5.851	<0.0001	0.296 (0.052)	5.653	<0.0001
Wave 3 primary caregiver stress						
Wave 1 primary caregiver stress	0.168 (0.051)	3.317	0.0009	0.173 (0.051)	3.387	0.0007
Family trauma	-0.121 (0.049)	-2.475	0.0133	-0.170 (0.070)	-2.438	0.0148
Primary caregiver trauma	0.245 (0.057)	4.331	<0.0001	0.227 (0.055)	4.144	<0.0001
Wave 2 primary caregiver PTSD	0.173 (0.053)	3.267	0.0011	0.048 (0.015)	3.184	0.0015
Wave 3 primary caregiver PTSD						
Primary caregiver trauma	0.142 (0.045)	3.129	0.0018	0.474 (0.156)	3.045	0.0023
Child age	0.081 (0.036)	2.285	0.0223	0.161 (0.070)	2.293	0.0218
Wave 1 primary caregiver PTSD	0.327 (0.047)	6.972	<0.0001	0.310 (0.045)	6.933	<0.0001
Wave 2 primary caregiver PTSD	0.293 (0.050)	5.851	<0.0001	0.294 (0.051)	5.722	<0.0001
Wave 3 primary caregiver stress	0.128 (0.046)	2.782	0.0054	0.462 (0.165)	2.798	0.0051
Harsh parenting						
Primary caregiver age	-0.119 (0.053)	-2.261	0.0238	-0.053 (0.023)	-2.333	0.0196
Wave 3 primary caregiver PTSD	0.120 (0.049)	2.434	0.0149	0.064 (0.027)	2.377	0.0175
Warm parenting	-0.177 (0.062)	-2.878	0.0040	-0.205 (0.068)	-2.998	0.0027
Emotional problems						
Female child	0.073 (0.031)	2.331	0.0198	0.328 (0.143)	2.298	0.0216
Wave 3 primary caregiver PTSD	0.144 (0.037)	3.876	0.0001	0.046 (0.012)	3.810	0.0001
Harsh parenting	0.340 (0.041)	8.334	<0.0001	0.205 (0.029)	7.120	<0.0001
Conduct problems						
Child age	-0.111 (0.033)	-3.390	0.0007	-0.050 (0.015)	-3.316	0.0009
Harsh parenting	0.409 (0.052)	7.844	<0.0001	0.174 (0.023)	7.721	<0.0001
Hyperactivity problems						
Child age	-0.112 (0.031)	-3.574	0.0004	-0.070 (0.020)	-3.549	0.0004
Female child	-0.099 (0.031)	-3.211	0.0013	-0.432 (0.135)	-3.209	0.0013
Harsh parenting	0.363 (0.040)	8.998	<0.0001	0.214 (0.028)	7.549	<0.0001
Peer problems						
Harsh parenting	0.182 (0.047)	3.849	0.0001	0.077 (0.020)	3.831	0.0001
Primary caregiver age						
Female primary caregiver	-0.292 (0.050)	-5.881	<0.0001	-5.766 (1.037)	-5.561	<0.0001

Shown are the dependent variables with their associated independent variables indented beneath them. Positive estimates indicate that an increase in the independent variable is associated with an increase in the dependent variable. Standardised estimates express this increase in standardised units of measurement and non-standardised in raw units of measurement. As such, under "Wave 1 primary caregiver PTSD", an increase in family trauma of 1 point increases PTSD by 0.725 points expressed in raw units, or 0.136 standardised units. Conversely, under "Harsh parenting", for each additional year of age, a primary caregiver reports 0.053 raw units (or 0.119 standardised units) less harsh parenting. Non-standardised estimates give the units of change in a dependent variable, for 1 unit of change in an independent variable, with change expressed in the original units of measurement (eg, levels of PTSD or years of age). Standardised estimates indicate these changes in standardised units of measurement, facilitating comparisons of the size of the association across different scales of measurement. PTSD=post-traumatic stress disorder.

Table 2: Standardised and non-standardised effects from caregiver trauma and postmigration difficulties to PTSD, parenting style, and child total difficulties

enough magnitude to mediate significant indirect PTSD associations with childhood mental health. Notably, an indirect path was reported between a caregiver's PTSD from several years earlier to the current level of caregiver PTSD, and subsequently to harsh parenting. This pattern highlights PTSD on subsequent child mental health via parenting behaviours. Notably, the indirect path from parental PTSD to children's psychological difficulties was stronger than the direct PTSD path (except in the case of emotional problems). Although some studies have found that interpersonal trauma contributes to maladaptive parenting in refugees and poor childhood mental health,¹⁰ no large representative studies of refugees have been done that address this question. A growing evidence base attests to the tendency for PTSD in refugee and post-conflict samples to be associated with anger,²⁶ which might contribute to harsh parenting. The anger and frustration difficulties associated with PTSD symptoms of refugees might directly contribute to the harsh parental behaviour that affects their children's internalising and externalising problems.

Notably, the analyses suggested that previous trauma and postmigration stressors affected later PTSD levels, which led to harsh parenting and consequent conduct, emotional, peer, and hyperactivity problems in the children. This supports an understanding of refugee mental health that highlights the crucial importance of the stress they experience in the host country in addition to premigration trauma,²⁷ and further extends this model by showing that child mental health is associated with the level of postmigration stress experienced by the family, including financial and employment difficulties.²⁸ Ongoing problems caused by financial, acculturation, legal, concern for family, or discrimination factors might interact with PTSD symptoms to heighten the risk for harsh parenting behaviour, which might directly contribute to poorer mental health in refugee children.²⁹ We also note that there might be bidirectional effects of caregiver and child mental health, and that parenting style might be shaped by the psychological state of the child; this possibility is supported by longitudinal evidence of the bidirectional influences of maternal and child mental health.³⁰

Although most of the association of PTSD and child mental health was mediated via increased use of negative parenting styles, we also found evidence for a direct association between caregiver PTSD and children's reported emotional difficulties. Several explanations might exist for this. First, the experience of PTSD might affect a range of caregiver and family factors that could directly influence the child's emotional wellbeing; for example, social withdrawal, dysphoria, and avoidance might negatively affect the child. Furthermore, PTSD could be associated with other factors that adversely affect children, including associated substance abuse, employment difficulties, and interpersonal conflict with other members of the family.³⁰ Interestingly, caregiver

PTSD directly affected children's emotional problems but not other domains of children's difficulties (which were affected via harsh parenting). This finding suggests that internalising emotional difficulties in children might be particularly susceptible to the ripple effects of parental PTSD over and above the effect of parental style. This possibility is suggested by other evidence that anxious parents can increase the anxiety levels of their children by engaging in overly protective behaviours of their children, conveying excessively negative appraisals about the world, or by modelling anxious behaviours to their children.³¹ Additionally, earlier stress reactions experienced by parents might have triggered epigenetic changes that subsequently resulted in vulnerability to mental health problems in the children.³² Some evidence suggests that parental PTSD can affect the methylation of a glucocorticoid receptor gene in offspring,³³ which could contribute to an intergenerational pathway between parental PTSD and mental health risk in offspring.

We note that, on the basis of parental reports, female children were more likely to report emotional problems than male children, and male children were more likely to be identified with hyperactivity symptom difficulties than female children. This pattern is consistent with many studies that have shown that internalising problems are more frequently seen in female participants and externalising problems in male participants.³⁴ We did not observe that parenting behaviour differentially affected boys and girls, which has been shown in some previous studies.³⁵ Younger age of children was associated with greater conduct disorders and hyperactivity, which accords with evidence that hyperactivity tends to decrease as children developmentally progress.³⁶

We note several methodological limitations. The sampling focused on those refugees who were granted permanent protection visas before arrival in Australia, with only a minority having applied for refugee protection via onshore asylum mechanisms. The sampling frame did not include any current asylum applicants, and the uncertainty of asylum outcome might involve different patterns (and potentially higher proportions of psychopathology) than seen in the current sample. Accordingly, most of the sample had not undergone many of the events often experienced by asylum seekers, including detention in refugee camps. Furthermore, most of the participants in the current sample were accompanied by family members, which might result in differences between the current sample and samples recruited from other regions that are characterised by different patterns of refugees resettling without family members. The preferential sampling of older children might also bias the sample to the extent that psychological problems often develop during adolescence.³⁷

We also note that assessment of psychological health in diverse cultural groups is challenging. Although the SDQ is the most widely used instrument to assess the psychological health of children and adolescents, some

evidence exists for its limited applicability in several cultural groups.³⁸ Relatedly, measurement of parenting cross-culturally is challenging and we acknowledge that our measure might not reflect all cultural parenting styles accurately. Furthermore, our reliance on the PTSD-8 precludes a full assessment of PTSD diagnostic criteria. Moreover, the BNLA research study did not assess other psychopathological states of parents, such as depression or somatisation disorders, which might differentially affect parenting style. Additionally, the BNLA did not index the potential effect of children's postmigration difficulties. We also recognise that by indexing harsh and warm parenting, we did not measure other facets of parenting behaviour (eg, over-protectiveness); other types of parenting could be usefully assessed in future studies of refugee family wellbeing.

Importantly, for ethical reasons, the BNLA did not directly ask children about their trauma histories, which precludes identification of pathways from personal trauma to childhood mental health. Whereas face-to-face interviews were conducted at Waves 1 and 3, Wave 2 was done via telephone; this difference might have attributed to the lower rates of PTSD noted at Wave 2. We also note the possibility of shared methods variance arising from parents completing measures of themselves and their children, especially at the same timepoint. Relatedly, the gender of parents might have influenced how parenting and perceptions of children's mental health were reported. Finally, the capacity for respondents to use the self-administered or interview-administered formats of the assessment might have introduced some variability; the study did not index when different formats were used because they were used according to participants' literacy and confidentiality needs in response to different questions. An element of response bias might also have been introduced during interview-administered formats because of concerns that some refugees might have had in reporting previous experiences, current symptoms, or parenting behaviours.

These limitations notwithstanding, this study provides initial evidence that the psychological wellbeing of refugees' children is associated with parental experiences of trauma, postmigration difficulties, and symptoms of traumatic stress. The nature of this effect is primarily mediated by the association between caregiver PTSD and greater use of harsh parenting styles, although associations between caregiver PTSD and child emotional problems was also evident. In view of the many millions of refugees across the world, this pattern highlights that the psychological wellbeing of many refugee children might be negatively affected by persistent mental health problems of refugee parents. Considering the opportunities available to reduce the stressors experienced in the postmigration setting, the current findings highlight the potential benefits for both refugees and their children via host countries implementing practices that minimise refugees' ongoing stressors. Addressing the psychological needs of

refugees and their parenting styles has the potential to not only assist adult refugees but might also have significant benefits for improving the psychological health of their children.

Contributors

RAB, BE, MC, MO'D, DF, KLF, DS, ZS, AN, ACM, and MVH contributed to the study concept and design. MO'D and DH-P managed the data. RAB, BE, MC, MO'D, DF, KLF, DS, ZS, AN, ACM, MVH, and DH-P analysed and interpreted the data. RAB, BE, MC, MO'D, DF, KLF, DS, ZS, AN, ACM, MVH, and DH-P drafted the manuscript. RAB, BE, MC, MO'D, DF, KLF, DS, ZS, AN, ACM, MVH, and DH-P critically revised the manuscript for important intellectual content. DH-P did the statistical analysis. RAB, MC, DS, KLF, and ACM obtained the funding. MO'D and BE supervised the study.

Declaration of interests

We declare no competing interests.

Acknowledgments

This research was funded by a National Health and Medical Research Council grant (1073041).

References

- 1 United Nations High Commissioner for Refugees. Figures at a glance. 2017. <http://www.unhcr.org/en-au/figures-at-a-glance.html> (accessed April 14, 2017).
- 2 Steel Z, Chey T, Silove D, Marnane C, Bryant RA, van Ommeren M. Association of torture and other potentially traumatic events with mental health outcomes among populations exposed to mass conflict and displacement: a systematic review and meta-analysis. *JAMA* 2009; **302**: 537–49.
- 3 Bronstein I, Montgomery P. Psychological distress in refugee children: a systematic review. *Clin Child Family Psychol Rev* 2011; **14**: 44–56.
- 4 Fazel M, Reed RV, Panter-Brick C, Stein A. Mental health of displaced and refugee children resettled in high-income countries: risk and protective factors. *Lancet* 2012; **379**: 266–82.
- 5 van Ijendoorn MH, Bakermans-Kranenburg MJ, Sagi-Schwartz A. Are children of Holocaust survivors less well-adapted? A meta-analytic investigation of secondary traumatization. *J Traum Stress* 2003; **16**: 459–69.
- 6 Ajdukovic M, Ajdukovic D. Psychological well-being of refugee children. *Child Abuse Negl* 1993; **17**: 843–54.
- 7 Rousseau C, Drapeau A, Corin E. Risk and protective factors in Central American and South East Asian refugee children. *J Refugee Stud* 1998; **11**: 20–37.
- 8 Lambert JE, Holzer J, Hasbun A. Association between parents' PTSD severity and children's psychological distress: a meta-analysis. *J Trauma Stress* 2014; **27**: 9–17.
- 9 McLeod BD, Weisz JR, Wood JJ. Examining the association between parenting and childhood depression: a meta-analysis. *Clin Psychol Rev* 2007; **27**: 986–1003.
- 10 Field NP, Muong S, Sochanvimean V. Parental styles in the intergenerational transmission of trauma stemming from the Khmer Rouge regime in Cambodia. *Am J Orthopsychiatry* 2013; **83**: 483–94.
- 11 Hinton DE, Rasmussen A, Nou L, Pollack MH, Good MJ. Anger, PTSD, and the nuclear family: a study of Cambodian refugees. *Soc Sci Med* 2009; **69**: 1387–94.
- 12 Thabet AA, Ibraheem AN, Shivram R, Winter EA, Vostanis P. Parenting support and PTSD in children of a war zone. *Int J Soc Psychiatry* 2009; **55**: 226–37.
- 13 Edwards B, Smart D, De Maio J, Silbert M, Jenkinson R. Cohort Profile: Building a New Life in Australia (BNLA): the longitudinal study of humanitarian migrants. *Int J Epidemiol* 2018; **47**: 20–28h.
- 14 Hansen M, Andersen TE, Armour C, Elklit A, Palic S, Mackrill T. PTSD-8: a short PTSD inventory. *Clin Pract Epidemiol Mental Health* 2010; **6**: 101–08.
- 15 Mollica RF. Measuring trauma, measuring torture: instructions and guidance on the utilization of the Harvard Program in Refugee Trauma's Versions of the Hopkins Symptom Checklist-25 (HSCL-25) & The Harvard Trauma Questionnaire (HTQ). Cambridge, MA: Harvard Program in Refugee Trauma, 2004.

- 16 Goodman R, Ford T, Simmons H, Gatward R, Meltzer H. Using the Strengths and Difficulties Questionnaire (SDQ) to screen for child psychiatric disorders in a community sample. *Brit J Psychiatry* 2000; **177**: 534–39.
- 17 Hollifield M, Warner TD, Lian N, et al. Measuring trauma and health status in refugees—a critical review. *JAMA* 2002; **288**: 611–21.
- 18 Zubrick SR, Lucas N, Westrupp, EM, Nicholson JM. Parenting measures in the longitudinal study of australian children: construct validity and measurement quality, waves 1 to 4. Canberra: Department of Social Services, 2014.
- 19 Paterson G, Sanson A. The association between behavioural adjustment to temperament, parenting and family characteristics among 5-year old children. *Soc Dev* 1999; **8**: 293–309.
- 20 US Department of Education. US childhood longitudinal study, birth cohort. Washington, DC: National Center for Education Statistics, 2001.
- 21 Bayer J, Sanson A, Hemphill S. Parent influences on early childhood internalizing difficulties. *J Appl Dev Psychol* 2006; **27**: 542–59.
- 22 Goodman R. Psychometric properties of the strengths and difficulties questionnaire. *J Am Acad Child Adolesc Psychiatry* 2001; **40**: 1337–45.
- 23 Richter J, Sagatun A, Heyerdahl S, Oppedal B, Roysamb E. The Strengths and Difficulties Questionnaire (SDQ)—self-report. An analysis of its structure in a multiethnic urban adolescent sample. *J Child Psychol Psychiatry* 2011; **52**: 1002–11.
- 24 Muthén LK, Muthén BO. Mplus user's guide, 6th edn. Los Angeles, CA: Muthén, & Muthén, 1998–2017.
- 25 Sack WH, Clarke GN, Seeley J. Posttraumatic stress disorder across two generations of Cambodian refugees. *J Am Acad Child Adol Psychiatry* 1995; **34**: 1160–66.
- 26 Spiller TR, Schick M, Schnyder U, Bryant RA, Nickerson A, Morina N. Somatisation and anger are associated with symptom severity of posttraumatic stress disorder in severely traumatised refugees and asylum seekers. *Swiss Med Wkly* 2016; **146**: w14311.
- 27 Porter M, Haslam N. Predisplacement and postdisplacement factors associated with mental health of refugees and internally displaced persons—a meta-analysis. *JAMA* 2005; **294**: 602–12.
- 28 Heptinstall E, Sethna V, Taylor E. PTSD and depression in refugee children: associations with pre-migration trauma and post-migration stress. *Europ Child Adol Psychiatry* 2004; **13**: 373–80.
- 29 Miller KE, Rasmussen A. War exposure, daily stressors, and mental health in conflict and post-conflict settings: bridging the divide between trauma-focused and psychosocial frameworks. *Soc Sci Med* 2010; **70**: 7–16.
- 30 Vogt D, Smith BN, Fox AB, Amoroso T, Taverna E, Schnurr PP. Consequences of PTSD for the work and family quality of life of female and male U.S. Afghanistan and Iraq War veterans. *Soc Psychiatry Psychiatr Epidemiol* 2017; **52**: 341–52.
- 31 Askew C, Field AP. The vicarious learning pathway to fear 40 years on. *Clin Psychol Rev* 2008; **28**: 1249–65.
- 32 Zannas AS, Provençal N, Binder EB. Epigenetics of posttraumatic stress disorder: current evidence, challenges, and future directions. *Biol Psychiatry* 2015; **78**: 327–35.
- 33 Yehuda R, Daskalakis NP, Lehrner A, et al. Influences of maternal and paternal PTSD on epigenetic regulation of the glucocorticoid receptor gene in Holocaust survivor offspring. *Am J Psychiatry* 2014; **171**: 872–80.
- 34 Washbrook E, Waldfogel J, Bradbury B, Corak M, Ghangro AA. The development of young children of immigrants in Australia, Canada, the United Kingdom, and the United States. *Child Dev* 2012; **83**: 1591–607.
- 35 van der Bruggen CO, Stams GJ, Bogels SM. Research review: the relation between child and parent anxiety and parental control: a meta-analytic review. *J Child Psychol Psychiatry* 2008; **49**: 1257–69.
- 36 Larsson H, Dilshad R, Lichtenstein P, Barker ED. Developmental trajectories of DSM-IV symptoms of attention-deficit/hyperactivity disorder: genetic effects, family risk and associated psychopathology. *J Child Psychol Psychiatry* 2011; **52**: 954–63.
- 37 Rapee RM, Schniering CA, Hudson JL. Anxiety disorders during childhood and adolescence: origins and treatment. *Annu Rev Clin Psychol* 2009; **5**: 311–41.
- 38 Stolk Y, Kaplan I, Szwarc J. Review of the strengths and difficulties questionnaire translated into languages spoken by children and adolescents of refugee background. *Int J Methods Psychiatr Res* 2017; **26**: e1568.